



Finally! Get rid of your old VAX without giving up your existing applications or special equipment.

We understand your dilemma: you want to free yourself of the maintenance overhead of your VAX, but you want to retain your investment in application software and I/O equipment. Now you can have both. With NuVAX your real-time applications can be running with a new CPU, memory, and mass storage devices without the hassle of hardware reconfiguration or software modification.



Eliminate

- *Obsolete disks and tapes*
- *High maintenance costs*
- *Unreliable equipment*



Preserve

- *Existing applications*
- *Specialized Qbus I/O interfaces*
- *Packaging and cables*



Improve

- *Performance up to 24 VUPS*
- *New equipment, new warranty*
- *High performance disk*



VAX Compatibility

- *Software compatible with existing applications*
- *Hardware compatible*
- *Diagnostic compatible*



Qbus Support

- *Support for multiple Qbus devices*
- *Follows all Qbus rules and specifications*
- *Both Qbus PIO and DMA data transfers are supported as well as all four Qbus interrupts*
- *Qbus PIO and DMA data transfers occur at maximum Qbus speeds. Throughput is limited only by the Qbus device(s).*



MVX-1000 - VAX on a Board

VAX on a board - MVX-1000 is a brand new processor that replaces your VAX processor, memory, disks and tape drives. Your current VAX disk images can be transferred onto MVX-1000's self-contained hard drive and run without modification. Existing specialized Qbus controllers and equipment are supported without any configuration changes. This model is ideal for applications embedded in computer bays where packaging and cabling changes are not practical. The MVX-1000 allows you to retain your VAX chassis, Qbus controllers, and cables.

Choose the NuVAX solution that best meets your requirements



MVX-3200 -Replacement System

NuVAX Replacement Systems are complete VAX system replacements for the VAX chassis, CPU, memory, and mass storage. Your current VAX disk images can be transferred onto a modern NuVAX system.

Two NuVAX systems are offered: MVX-2000 consists of the MVX-1000 installed in a brand new Qbus chassis with space for your Qbus controllers. The MVX-3200 allows you to replace your entire system with an industry-standard platform offering updated versions of popular legacy Qbus interfaces.

MVX-1000

VAX on a Board



Drop a new engine in your MicroVAX. Installed in your MicroVAX, the MVX-1000 replaces your processor, memory, and hard drives with a new state-of-the-art processor, memory and hard drive. The MVX-1000 provides up to 18 VUPS to support the most demanding applications and provides a Qbus interface to support the wide variety of DMA, PIO, and interrupt Qbus controllers.

MVX-1000 allows you to preserve your investment in hardware and software while increasing performance, improving reliability, and lowering maintenance costs. MVX-1000 is designed to prolong the use of VAX applications by upgrading MicroVAX systems in applications that depend on Qbus controller cards and the devices attached to these controllers.

➤ **Replace all of these:**

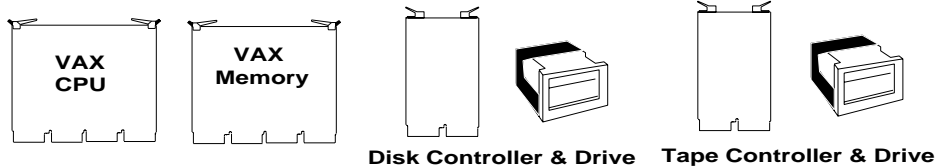

➤ **With MVX-1000**



➤ **Your specialized Qbus controllers remain in the VAX**

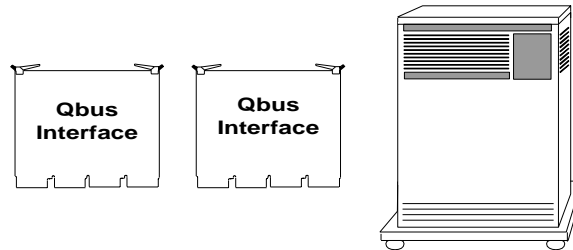

➤ **And your performance increases to up to 18 VUPS compared to the 3 VUPS of the MicroVAX 3600.**

MVX-2000

VAX Replacement Systems



Replace your MicroVAX with a brand new system. The MVX-2000 replaces the MicroVAX systems' processor, memory, and hard drives with a new state-of-the-art system while allowing you to retain your existing Qbus controllers. The MVX-2000 consists of all new equipment: a Qbus chassis with power supply and Qbus backplane; an MVX-1000 processor with memory and disks; and five available quad-width slots (or eight dual-width slots) for your Qbus controllers.

MVX-2000 allows you to preserve your investment in hardware and software while increasing performance, improving reliability, and lowering maintenance costs. MVX-2000 is designed to prolong the use of VAX applications by upgrading MicroVAX systems in applications that depend on Qbus controller cards and the devices attached to these controllers.

➤ **Replace all of these:**

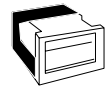
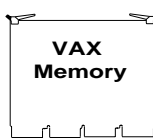
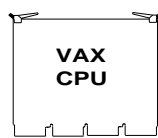

Disk Controller & Drive

Tape Controller & Drive

➤ **With MVX-2000**



➤ **Retain your specialized Qbus controllers**

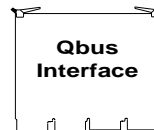
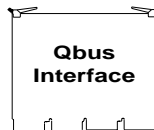

➤ **And your performance increases to up to 18 VUPS compared to the 3 VUPS of the MicroVAX 3600.**

MVX-3200

VAX Replacement Systems



Replace your MicroVAX and Qbus controllers with brand new equipment. The MVX-3200 is a complete state-of-the-art system that replaces your outmoded VAX with its slow memory and hard-to-maintain disks and tapes. MVX-3200 allows you to run your existing application software and offers updated versions of DEC I/O interfaces.

Complete State-of-the-Art System

- The MVX-3200 system offers a removable SATA system drive and an optional removable data drive.
- Supports up to 64 MB VAX memory.
- OpenVMS-compatible CD-ROM.
- Supports Fast Ethernet adapters for 100 Mbps network connections to other systems using OpenVMS network protocols like DECnet and TCP/IP.
- Offers your choice of DRV11, DRV11-J, DRV11-WA, DRQ3B, IEQ11, Ethernet, and serial communications interfaces. Other interfaces can be designed for your application. Ask your sales representative about your special requirements.
- Supports speeds up to 24 VUPS

QP Option Modules

QP option modules are offered to replace popular DEC I/O interfaces. Custom modules can be designed for your application as special projects. Check with your sales representative for more information about special projects.

DRQ3B	DQP-1500-AA
DRQ3B with DRPI	DQP-1501-AA
DRV11	DQP-1300-AA
DRV11-J	DQP-1400-AA
DRV11-WA	DQP-1100-AA Standard DQP-1100-AB Long Line
DHV11, DHQ11, DZQ11, CXY08	CCI-0008-AA
DELQA (dual port)	CEI-2000-A
IEQ11-A	DQP-3100-AA
External Unibus Support Adapter	AQP-2302-AA



QP Option Module

MVX-3200

VAX Replacement Systems

➤ **Replace all of these:**

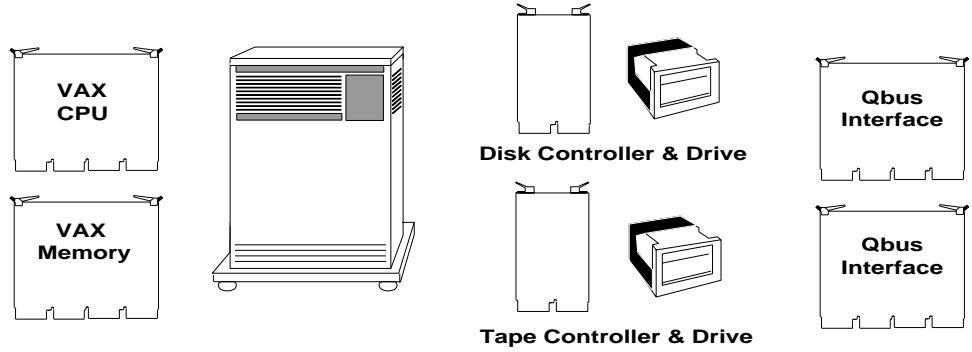

➤ **With the MVX-3200 model that fits your application**



Model	MVX-3200-AA	MVX-3200-AB	MVX-3200-BA	MVX-3200-BB
Added Data Drive		√		√
External Qbus Support			√	√
External Unibus Support	Optional	Optional	Optional	Optional

➤ **Optional External Unibus support:**

Retain Unibus equipment with the AQP-2302 external Unibus adapter and a Unibus chassis.

	MVX-1000	MVX-2000	MVX-3200
Physical	Standard quad-width board, 26.7 cm by 21.3 cm. Requires 4 quad-width Qbus slots to install.	Chassis measuring 13.4 cm x 48.3 cm x 43.2 cm (5.25" x 19" x 17")	Standard 4U rack-mount chassis (20 inch depth)
Processors Supported	MicroVAX II, MicroVAX 3300, 3400, 3500, 3600, 3800, and 3900		
Disks Emulated	RQZX1, RQDX3, RQDX2, QDA50		
Tapes Emulated	TQK50, TQK70		
VAX Memory	64 MB		
Hard Drive	Two IDE ATA 100 ports, one port reserved	Two IDE ATA100 ports, one port reserved	Removable 80GB SATA drive - one system drive, one optional data drive
Ethernet	Two ports: <ul style="list-style-type: none"> • One DELQA emulation • One reserved 	Two ports: <ul style="list-style-type: none"> • One DELQA emulation • One reserved 	10/100 port for DELQA emulation
RS232 Serial Port (COM1,COM2)	Console (TT0) and DLV11 (TT1)		Console (TT0) only
• Speed	38.4 Kb maximum		
USB	Reserved		
Keyboard, VGA	Not supported		
Mouse	Not supported		
Printer	LPV11		
Power	5.5 amps @+5 VDC	250 W @ 115/230 VAC, 50/60 Hz auto-sensing	300 W @ 115/230 VAC, 50/60 Hz auto-sensing
QP Slots for I/O	None	None	5
Qbus Slots for I/O	System specific	5 quad-width	NA
Qbus Loading	1dc load, 2 ac loads		NA
Qbus Drive Capability	19 additional dc loads		NA
VAX/VMS License	Qualifies for transfer		
Operating Environment			
• Temperature	10° to 50° C (50° to 120° F)		
• Relative Humidity	10 to 90% non-condensing		
Storage Environment			
• Temperature	-40° to 60° C (-40° to 140° F)		
• Relative Humidity	5% to 90% non-condensing		

MVX-1000 - VAX on a Board



Model	Description
MVX-1000-AA	MicroVAX replacement controller consist of a quad-width Qbus module with CPU, hard drive, memory, and license/key. Requires 4 Qbus slots for BA23 and BA123. Requires 3 Qbus slots for the BA2xx style enclosures.

MVX-2000 - VAX Replacement System



Model	Description
MVX-2000-AA	MicroVAX replacement system consisting of an MVX-1000-AA in a Qbus chassis with 5 available quad-width Qbus slots. Includes slides for rack mounting.

MVX-3200 - VAX Replacement Systems



Model	Features	Description
MVX-3200-AA	Standard System	MicroVAX replacement system with a removable system drive. Supports up to 5 QP option modules. Includes slides for rack mounting.
MVX-3200-AB	System with Removable Data Drive	MicroVAX replacement system with a removable system drive and a removable data drive. Supports up to 5 QP option modules. Includes slides for rack mounting.
MVX-3200-BA	System with External Qbus Support	MicroVAX replacement system with a removable system drive and support for an external Qbus. Supports up to 5 QP option modules. Includes slides for rack mounting and a Qbus interconnect kit. Order Qbus expansion chassis separately.
MVX-3200-BB	System with Removable Data Drive and External Qbus Support	MicroVAX replacement system with a removable system drive, a removable data drive and support for an external Qbus. Supports up to 5 QP option modules. Includes slides for rack mounting and a Qbus interconnect kit. Order Qbus expansion chassis separately.



QP option modules are plug-and-play replacements for popular legacy Digital interfaces. Option modules install in a MVX-3200 system and offer the same functionality as the Digital equivalent, thus allowing users to migrate from their Qbus systems to 3200 systems and maintain their investment in software and user equipment.



New Technology

- *State-of-the-art design*
- *New equipment, new warranty*



Software Compatible

- *Application compatible*
- *Diagnostic compatible*



Hardware Compatible

- *Signal compatible*
- *Connector & switch compatible*
- *Use existing user cables and equipment*

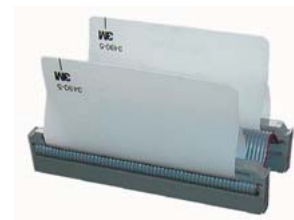

QP Interconnect

QP option modules install into a single slot and connect to the NuVAX bus adapter and, optionally, other QP option modules by way of QP interconnects.

Digital Module	Digital Interface	Part Number
M3104	DHV11	CCI-0008-AA
M3106	DZQ11	CCI-0008-AA
M3107	DHQ11	CCI-0008-AA
M3119	CXY08	CCI-0008-AA
M7516	DELQA	CEI-2000-A
M7651	DRV11-WA	DQP-1100-AA
M7651 + M9056	DRV11-WA + Long Line	DQP-1100 AB
M7658	DRQ3B	DQP-1500-AA
M7658 + APG-63(V)1	DRQ3B + DRPI	DQP-1501-AA
M7941	DRV11	DQP-1300-AA
M8049	DRV11-J	DQP-1400-AA
M8634	IEQ11-A	DQP-3100-AA

DQP-1100

DEC Module	M7651 + M9056 for differential
Interface Name	DRV11-WA
Function	16-bit parallel user interface for PIO and DMA transfers between a Qbus system and external equipment. It can also serve as a link between a Qbus system and another computer with a DRV11-WA or DR11-W compatible interface. 22-bit addressing capability and permits data transfers at rates up to 400 Kbps in burst mode
Power	0.5 amps @ +5V, 0.3 amps @ +3.3V
User Connection	Two 40-pin connectors, two 60-pin connectors for differential
Part No: DQP-1100-AA	Standard package includes controller, QP interconnect, adapter panel, adapter cable, and test cable.
Part No: DQP-1100-AB	Differential Package includes controller, QP interconnect, differential adapter panel, adapter cable, and test cable.



DQP-1300

DEC Module	M7941
Interface Name	DRV11
Function	16-bit parallel user interface for transfers between a Qbus system and parallel line TTL-based user equipment. It can also serve as a link between a Qbus system and another computer with a DRV11 or DR11-C compatible interface.
Power	0.5 amps @ +5V, 0.3 amps @ +3.3V
User Connection	Two 40-pin connectors
Part No: DQP-1300-AA	Standard package includes controller, QP interconnect, adapter panel, adapter cable, and test cable.



DQP-1400

DEC Module	M8049
Interface Name	DRV11-J
Function	Parallel interface that provides 64 input/output data lines. Interrupt ability up to 16 lines with programmable interrupt vectors and program selection of fixed or rotating interrupt priority.
Power	0.5 amps @ +5V, 0.3 amps @ +3.3V
User Connection	Two 50-pin connectors
Part No: DQP-1400-AA	Includes controller, QP interconnect, adapter panel, adapter cable, and test cable.



DQP-1500	
DEC Module	M7658
Interface Name	DRQ3B
Function	High performance 16-bit parallel interface designed for real-time data collection or for high-speed inter-processor communications. It provides PIO and DMA transfers between a Qbus system and external equipment at transfer rates of up to 1.3 MHz of 16-bit words.
Power	1 amp @ +5V, 0.3 amps @ +3.3V
User Connection	Two 50-pin connectors
Part No: DQP-1500-AA	Standard package includes controller, QP interconnect, adapter panel, adapter cable, and test cable.



DQP-1501	
DEC Module	M7658 plus APG-63(V)1
Interface Name	DRQ3B plus DRPI
Function	Like the DRQ3B, the DQP-1501 is a high performance 16-bit parallel interface designed for real-time data collection or for high-speed interprocessor communications. It provides PIO and DMA transfers to the DRPI interface at transfer rates of up to 1.3 MHz of 16-bit words. Plug-and-play replacement for the APG-63(V)1 Radar Data Processor (DRPI) controller.
Power	1 amp @ +5V, 0.3 amps @ +3.3V
User Connection	One 50-pin HD SCSI connector
Part No: DQP-1501-AA	Standard package includes controller and QP interconnect.





DQP-3100	
DEC Module	M8634
Interface Name	IEQ11
Function	DMA controller that interfaces a Qbus system to two independent channels that are compatible with both the IEC and IEEE instrument buses. The instrument buses conform to both the European Standard IEC 625-1 and the U. S. Standard IEEE 488.1-1987. Each instrument bus can have up to fifteen devices, including the DQP-3100, in a sequential configuration.
Power	0.5 amps @ +5V, 0.3 amps @ +3.3V
User Connection	IEEE IEEE-488 standard 24-pin connector IEC IEC-625 standard 25-pin connector One connector per channel.
Part No: DQP-3100-AA	Includes controller, QP interconnect, and IEC to IEEE488 cables. Requires two rear-panel exit slots for two-line operation



MVX-3200

Option Modules

CCI-0008		
DEC Module	M3104, M3106, M3107, M3119	
Interface Name	DHV11, DZQ11, DHQ11, CXY08	
Function	8-port RS232/RS422 asynchronous communication controller with external DB25 user connection.	
Power	1.8 amps @ +5V	
User Connection	Eight DB25-P connectors	
Line Parameters	Data bits: 5, 6, 7, 8 Stop bits: 1, 1.5, 2 Parity: Odd, even, or no parity Baud Rates: 50, 75, 110, 134.5, 150, 300, 600, 1200, 1800, 2000, 2400, 4800, 7200, 9600, 19.2K, 38.4K bps.	
Part No: CCI-0008-AA	Standard package includes controller, DB25 octopus cable, and test cables.	

CEI-2000		
DEC Module	M7516	
Interface Name	DELQA	
Function	Dual-port Ethernet controller that enables higher-level software protocols, such as DECnet, to communicate over an Ethernet network. The CEI-2000 conforms with the IEEE Specification 802.3 for Local Area Networks	
Power	1.0 amp @ +5V	
User Connection	Two RJ45 Ethernet connectors	
Part No: CEI-2000-A	Dual-port PCI Ethernet controller.	

AQP-2302		
Function	External Unibus adapter allows Unibus controllers in an external chassis to be accessed from the NuVAX system.	
Power	2.5 amps @ +5V, 0.5 amps @ +3.3V	
Part No: AQP-2302-AA	Includes controller, QP interconnect, Unibus module, adapter panel and adapter cables.	



For more information, contact:
Salem Automation Inc.
4500 Indiana Ave, Suite 40
Winston-Salem NC 27106

Tel: 336-661-0890
Fax: 336-661-9575

Sales:
Main contact, Southeast & Western US:
Chuck Graham - VP Sales & Marketing
email: cwgraham@sai-net.com
Office: (336) 661-0890, ext 106

Northeast US Boston, MA Area Office:
Bob Gyles - Northeast Regional Sales Manager
Office: (978) 425-2582

Western US Phoenix, AZ Area Office:
John Mercier - Western Regional Sales Manager
Office: (480) 633-5739

General Information:
Jean Brunache 336 661 0890, ext 116